

WSA series 0-5V voltage output inclinometer

Product introduction

Woosens WSA series 0~5V voltage output inclinometer is a cost-effective inclinometer module. It is made by high-accuracy accelerometer MEMS device and standard MCU, built-in advanced anti-vibration filtering algorithms. The product has undergone strict production calibration, factory inspection, to ensure excellent product consistency and reliability.



WOOSENS WSA series voltage output inclinometer module with spring and horizontal air bubble. Designed in the unique spring profile, WSA series allow users to detect whether it works properly via press of the spring. The horizontal air bubble integrated in the up-cover is very convenient to installation and adjustment. It adopts 0~5V standard interface, which can be directly connected to various industrial control hosts. It has excellent load capacity and anti-interference ability. The sensor adopts indicators light to show the working status, convenient for customers.

Features

- 0~5V Linear voltage output
- light indicates the working status
- Spring detect working status
- Range $\pm 15^\circ/\pm 30^\circ/\pm 90^\circ$ optional
- IP65 Protection
- Horizontal air bubble easy to adjustment
- Operating temperature -40~85°C
- RoHS
- Power supply: 9~35V

Application

- Angle measurement
- Engineering machinery
- Horizontal adjustment, zero-alignment
- Equipment and Instrument Status Monitoring

Product specification

Electrical Specification

Parameter	Condition	Minimum	Typical	Maximum	Unit
Power supply	Wide voltage	9	12	35	V
Operating current		20		30	mA
Operating temperature		-40		+85	°C
Store temperature		-40		+100	°C

Performance Specification

Parameter	Condition	Specification
Measuring axis		X-Y
Measuring range		$\pm 15^\circ/\pm 30^\circ/\pm 90^\circ$
Output voltage @ 0°		2.5V
Output voltage range		0.5~4.5V
Frequency response		10Hz
Sensitivity	$\pm 15^\circ$ Range	133mV/°
	$\pm 30^\circ$ Range	66.7mV/°
	$\pm 90^\circ$ Range	22mV/°
Temperature drift	-40-80°C	0.008°/°C

Note: All parameters are measured at room temperature 25°C.

Mechanical Characteristic

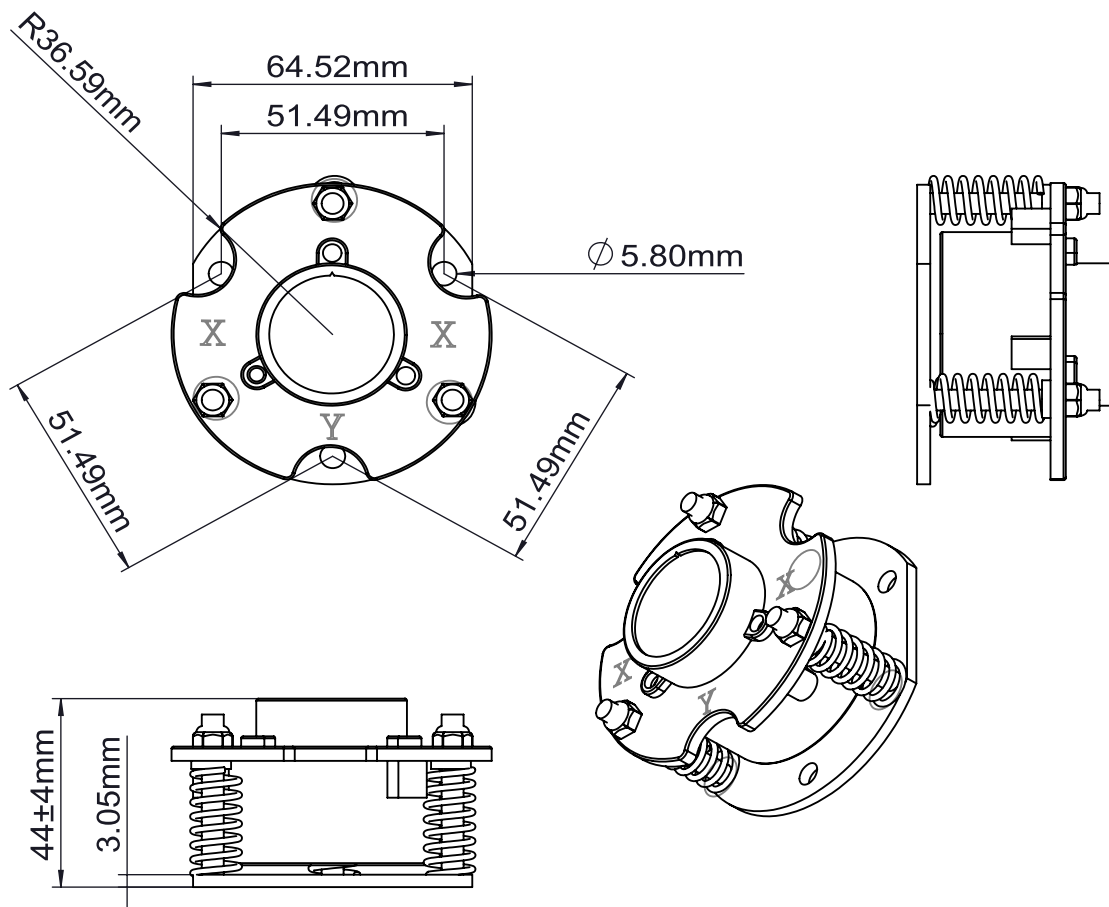

Installation direction

Colour	Red	Yellow	Green	Black
Function	VIN	X-OUT	Y-OUT	GND
Colour	Brown	Blue		
Function	TXD	RXD		

Note: RXD and TXD are the interfaces used for factory calibration, and users do not need to use them

Transform Voltage Into Angle

$$\text{Angle}(\text{°}) = (\text{Vout}(\text{@Angle}) - \text{Vout}(\text{@0°})) / \text{Vsensitivity}$$

Example:

Measuring range is $\pm 90^\circ$, Sensitivity is $22\text{mV}/^\circ$, the actual measurement X axis output voltage is 4V, the actual measurement Output voltage is 2.5V, so X axis Angle($^\circ$) = $(4000 - 2500) / 22 = 68.18^\circ$

Ordering information

Measuring range	Measuring axis	Part number
$\pm 15^\circ$	Single-Axis/Dual-Axis	WSA111-N15S/WSA121-N15S
$\pm 30^\circ$	Single-Axis/Dual-Axis	WSA111-N30S/WSA121-N30S
$\pm 90^\circ$	Single-Axis/Dual-Axis	WSA111-N90S/WSA121-N90S

Indicator light description

Condition	Red light	Green light	Comments
Normal	Off	On	Indicates that the angle is within the alarm threshold
Normal turn to alarm	Off	Flashing	Indicates that the angle exceeds the threshold from within the alarm threshold
Alarm	On	Off	Indicates that the angle is outside the alarm threshold
Alarm turn to Normal	Flashing	Off	Indicates that the angle recovers from outside the alarm threshold to within the threshold

Setup guide

Zero Setting:

1. Find the zeroing hole to the left of the outlet direction.
2. Use the zeroing tool to insert the zeroing hole and hold down the button. You can see the red and green lights flashing alternately (at this time, the zeroing operation can be performed).
3. Keep the red and green lights blinking alternately and observe the indicator light status change: The red and green lights blinking alternately change to steady on at the same time. Release the zeroing tool. Then insert the zeroing tool into the zeroing hole and press it continuously for three times. The red and green light flashes alternately until it turns green and is independently steady on. Then remove the zeroing tool.
4. Turn off the power.
5. Turn on the power again, and confirm that the green light is on, indicating that the zero setting operation is successful. If the red indicator is on, it means that the zero-setting operation has failed, and you need to go back to the first step to perform the zero-setting operation again.

Recommend: Need Zero setting in following situation

- 1.The sensor has just been installed
- 2.Compared with the last zero setting, the temperature increased or decreased by more than 15°C

Note: All Specifications are subjected to change without notice.