

WTAL Series 4-20mA current output inclinometer

Product introduction

Woosens WTAL series current output inclinometer module which made by high-accuracy accelerometer MEMS device and standard MCU, built-in advanced anti-vibration filtering algorithms. The product has undergone strict production calibration, factory inspection, to ensure excellent product consistency and reliability.



WOOSENS WTAL series current output inclinometer module adopts 4~20mA standard interface, which can be directly connected to various industrial control hosts. Housing in an engineering plastics case with dual colour indicator light and One key zero-setting function, the WTAL series inclinometer provides IP65 rated waterproof, It has excellent load capacity and anti-interference ability.

I Features

- High precision, high stability
- Dual colour indicator light
- One key zero-setting function
- IP65 Protection
- 3D MEMS sensor
- RoHS

I Application

- Angle measurement
- Construction vehicle
- Engineering machinery
- Equipment and Instrument Status Monitoring

Product specification

Electrical Specification

Parameter	Condition	Minimum	Typical	Maximum	Unit
Power supply	Wide voltage	9	12	35	V
Operating current		20		30	mA
Operating temperature		-40		+85	°C
Store temperature		-40		+100	°C

Performance Specification

Parameter	Condition	Specification
Measuring axis		X-Y(360°Measuring range is uniaxial only)
Measuring range		$\pm 15^\circ/\pm 30^\circ/\pm 45^\circ/\pm 90^\circ/0-360^\circ$
Output current @ 0°		12mA
Output current range		4~20mA
Frequency response		5Hz
Sensitivity	$\pm 15^\circ$ Range	0.53mA/°
	$\pm 30^\circ$ Range	0.27mA/°
	$\pm 45^\circ$ Range	0.17mA/°
	$\pm 90^\circ$ Range	0.089mA/°
	0-360°Range	0.045mA/°
Default communication Settings		9600, n, 8, 1

Note: All parameters are measured at room temperature 25°C.

Mechanical Characteristic

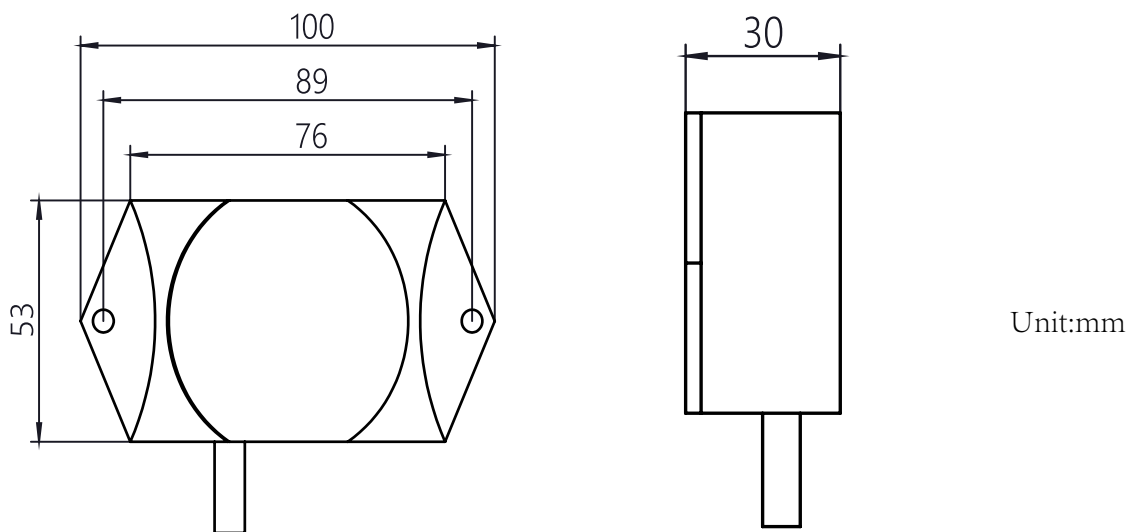

Interface Definition

Interface	Red	Yellow	Green	Black
Function	VIN	X-OUT	Y-OUT	GND
Interface	Grey	White	Brown	
Function	TXD	RXD	Reference GND	

Note: RXD and TXD are the interfaces used for factory calibration, and users do not need to use them.

Installation direction

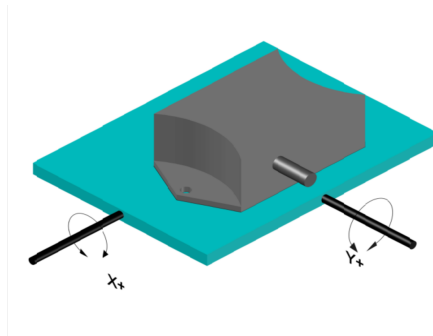

Formula: Transform Current Into Angle

$Angle(^{\circ}) = (I_{out}(@Angle) - I_{out}(@0^{\circ})) / \text{sensitivity}$

Example:

Measuring range is $\pm 90^{\circ}$, Sensitivity is $0.089\text{mA}/^{\circ}$, the actual measurement X axis output current is 16mA , the actual measurement Output current @ 0° is 12mA , so X axis $Angle(^{\circ}) = (16 - 12) / 0.089 = 45^{\circ}$

Ordering information

Measuring range	Measuring axis	Part number
$\pm 15^{\circ}$	Single-Axis/Dual-Axis	WTAL114-N15K/WTAL124-N15K
$\pm 30^{\circ}$	Single-Axis/Dual-Axis	WTAL114-N30K/WTAL124-N30K
$\pm 45^{\circ}$	Single-Axis/Dual-Axis	WTAL114-N45K/WTAL124-N45K
$\pm 90^{\circ}$	Single-Axis/Dual-Axis	WTAL114-N90K/WTAL124-N90K
$0 \sim 360^{\circ}$	Single-Axis	WTAL114-N36K

Indicator light description

Condition	Red light	Green light	Comments
Normal	Off	On	Indicates that the angle is within the alarm threshold
Normal turn to alarm	Off	Flashing	Indicates that the angle exceeds the threshold from within the alarm threshold
Alarm	On	Off	Indicates that the angle is outside the alarm threshold
Alarm turn to Normal	Flashing	Off	Indicates that the angle recovers from outside the alarm threshold to within the threshold

Zero Setting:

1. Find the zeroing hole to the left of the outlet direction.
2. Use the zeroing tool to insert the zeroing hole and hold down the button. You can see the red and green lights flashing alternately (at this time, the zeroing operation can be performed).
3. Keep the red and green lights flashing alternately, while observing the status changes of the indicator lights: from the red and green lights flash alternately and turn into steady red and green light on at the same time, and remove the zero-setting tool until the green light alone is always on;
4. Turn off the power.
5. Turn on the power again, and confirm that the green light is on, indicating that the zero setting operation is successful. If the red indicator is on, it means that the zero-setting operation has failed, and you need to go back to the first step to perform the zero-setting operation again.

Recommend: Need Zero setting in following situation

1. The sensor has just been installed
2. Compared with the last zero setting, the temperature increased or decreased by more than 15°C

Note: All Specifications are subjected to change without notice.