

WOO Series LCD inclinometer module



WOO Series Features >>

- High precision, high stability
- Measurement Angle digital display
- 12V power supply
- Integrated rechargeable battery
- Base with magnet, absorb metal surface
- Biaxial measurement
- RS232,RS485 interface optional
- Aluminum alloy housing

Application >>

- Inclination measurement
- Construction machinery
- Machinery leveling
- Installation engineering
- Building construction
- Surveying and mapping instrument
- Horizontal adjustment, zero-alignment

Product introduction

WOOSENS WOO series LCD inclinometer is High precision, high stability inclinometer module. it made by high- accuracy acclerometer MEMS device and standard MCU, built-in advanced anti-vibrtion filtering algorithms. The product has undergone trict production calibration, factory inspection, to ensure excellent product consistency and reliability.



WOOSENS WOO series LCD inclinometer can directly display measurement data. It also has two standard interface outputs: RS232 and RS485. According to the actual situation of the system, the appropriate output interface is selected. All modules adopt the standard MODBUS-RTU protocol, which is particularly convenient for customers who use bus communication and is compatible with other standard protocol modules.

Product specification

◆ Electrical Specification

| Parameter | Condition | Minimum | Typical | Maximum | Unit |
|-------------------|----------------|---------|---------|---------|------|
| Power supply | Single voltage | | 12 | | V |
| Operating current | | | | 90 | mA |
| Operating temp. | | -40 | | +80 | °C |
| Store temp. | | -40 | | +100 | °C |

◆ Performance Specification

| Parameter | Condition | Specification |
|------------------------|----------------|----------------------|
| Measuring axis | | X-Y |
| Measuring range | | ±15°/±30°/±90° |
| Output resolution | | 0.002°/0.004°/0.009° |
| Repeatability | | 0.01°/0.02°/0.10° |
| Zero point error | | Max.0.1° |
| Cross axis error | | Max4%,tye2% |
| Frequency response | | 10Hz |
| Relative accuracy | ±15°Range | 0.02° |
| | ±30°Range | 0.04° |
| | ±90°Range<±15° | 0.06° |
| | ±90°Range<±60° | 0.08° |
| | ±90°Range>±60° | 0.15° |
| Temperature drift | -40~80°C | Max0.008°/°C |
| Communication Settings | | 9600,n,8,1 |

Note: All patameters are measured at room temperature 25°C.

Mechanical Characteristic

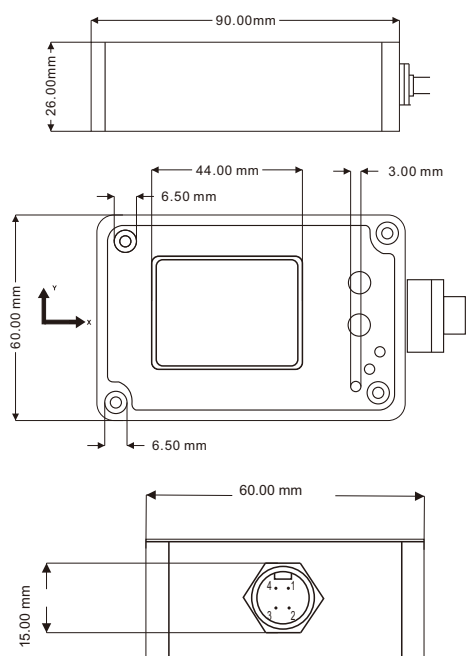

- | | |
|--------------|--------------|
| 1. Red VIN | 3. Blue TX |
| 2. Yellow RX | 4. Black GND |

Interface Definition

Woo series pluggable connector is P type connector, which needs connecting wire 115-10011-422A, power adapter model 121-12102-IP67.

| Interface | Red | Yellow | Blue | Black |
|-----------|-----|--------|------|-------|
| RS232 | VIN | RX | TX | GND |
| RS485 | VIN | A/D+ | B/D- | GND |

Ordering information

RS232 Interface

| Range | Measuring axis | Part number |
|-------|----------------|-------------|
| ±15° | Dual-Axis | Woo123-L15H |
| ±30° | Dual-Axis | Woo123-L30H |
| ±90° | Dual-Axis | Woo123-L90H |

RS485 Interface

| Range | Measuring axis | Part number |
|-------|----------------|-------------|
| ±15° | Dual-Axis | Woo125-L15H |
| ±30° | Dual-Axis | Woo125-L30H |
| ±90° | Dual-Axis | Woo125-L90H |

Instructions

1. Turn on/off: Press and hold the ON/OFF button for 1 second, and a countdown will appear. After the timing is completed, it will enter the measurement mode; in the measurement mode, press and hold the ON/OFF key for 2s to shut down.
 2. Measurement: in the measurement mode, press and hold the ZERO button for 2s to display will be turned off until the indicator is turned on again and the yellow indicator light is on, that is, the measurement mode is successfully entered. Long press the key again, the display and the yellow indicator light will go out, and the measurement mode will exit when the display is turned on again.
 3. Zero point calibration: Place the product on a flat surface and measurement mode, at the same time, long press the ON/OFF and ZERO buttons for 2 seconds to enter the zero point calibration mode. The first line of the display shows "F---1" and the second line shows "CAL-1". At this time, short press the ZERO key to calibrate the first point. After completion, the second line will display "-O-K-", and after 1 second, it will display "CAL-2". Rotate 180° at the same position, short press the ZERO button again to complete the second point calibration, the second line displays "-O-K-", and close the display after 1s to save the data. After completion, the display lights up again.
 4. Zero point clearing: In the shutdown state, press and hold ON/OFF and press ZERO for 2s to enter the zero clear mode, the first line of the display shows "F--- 2", and the second line shows "-CLR-". Short press the ZERO button to complete the clearing. The second line of the display shows "-O-K-", and the display will be turned off after 1s to save the data. After completion, it will enter the power-on measurement mode..
 5. Low voltage: When the voltage is low, the blue indicator light will flicker to remind the user that the voltage is low and needs to be charged in time.
 6. Charging indicator: when charging, the red indicator light is on, when fully charged the green indicator light is on.
 7. Power saving mode: In power saving mode, the display will wake up periodically display the current angle, the period can be set (default 5 minutes), and the display duration can be set (default 3s). When the angle change is greater than 0.5°, the power saving mode is automatically exited.
- Note:** In any setting state, if there is no operation for 30s, it will automatically exit the setting state. When the angle change is less than 0.5° for 5 minutes (default), the display will turn off and enter the power saving mode.