

# WSS series inclinometer switch

## Product introduction

Woosens WSS series inclinometer switch is a cost-effective inclinometer module. It is made by high-accuracy accelerometer MEMS device and standard MCU, built-in advanced anti-vibration filtering algorithms. The product has undergone strict production calibration, factory inspection, to ensure excellent product consistency and reliability.



WOOSENS WSS series inclinometer switch with spring and horizontal air bubble. Designed in the unique spring profile, WSS series allow users to detect whether it works properly via press of the spring. The horizontal air bubble integrated in the up-cover is very convenient to installation and adjustment. WSS series inclinometer switch has switching signal output interface. The delay times of alarm and alarm-remove can be customized according to the actual situation. The module is a high accuracy, high stability product, It is widely used in engineering machinery industry.

### Features

- Dual colour indicator light
- One key zero-setting function
- Dual axis measurement with switching signal output
- Delay times of alarm and alarm-remove can be customized
- Unique spring design, detect works condition
- Horizontal air bubble integrated, convenient to adjustment
- IP65 protection with Engineering plastics housing

### Application

Aerial work platform   Crane and lifts   Automatic positioning platform

## Product specification

### Electrical Specification

Parameter	Condition	Minimum	Typical	Maximum	Unit
Power supply	Wide voltage	9	12	35	V
Operating current		20		40	mA
Operating temperature		-40		+80	°C
Store temperature		-40		+100	°C

**Performance Specification**

Parameter	Condition	Specification
Measuring axis		X-Y
Measuring range		± 30°
Output resolution		0.01°
Repeatability		0.02°
Frequency response		10Hz
Relative accuracy	±30°Measuring range	0.1°
Temperature drift	-40-80°C	0.008°/°C
Weight		250g

Note: The relative accuracy is measured at room temperature 25°C.

**Mechanical Characteristic**

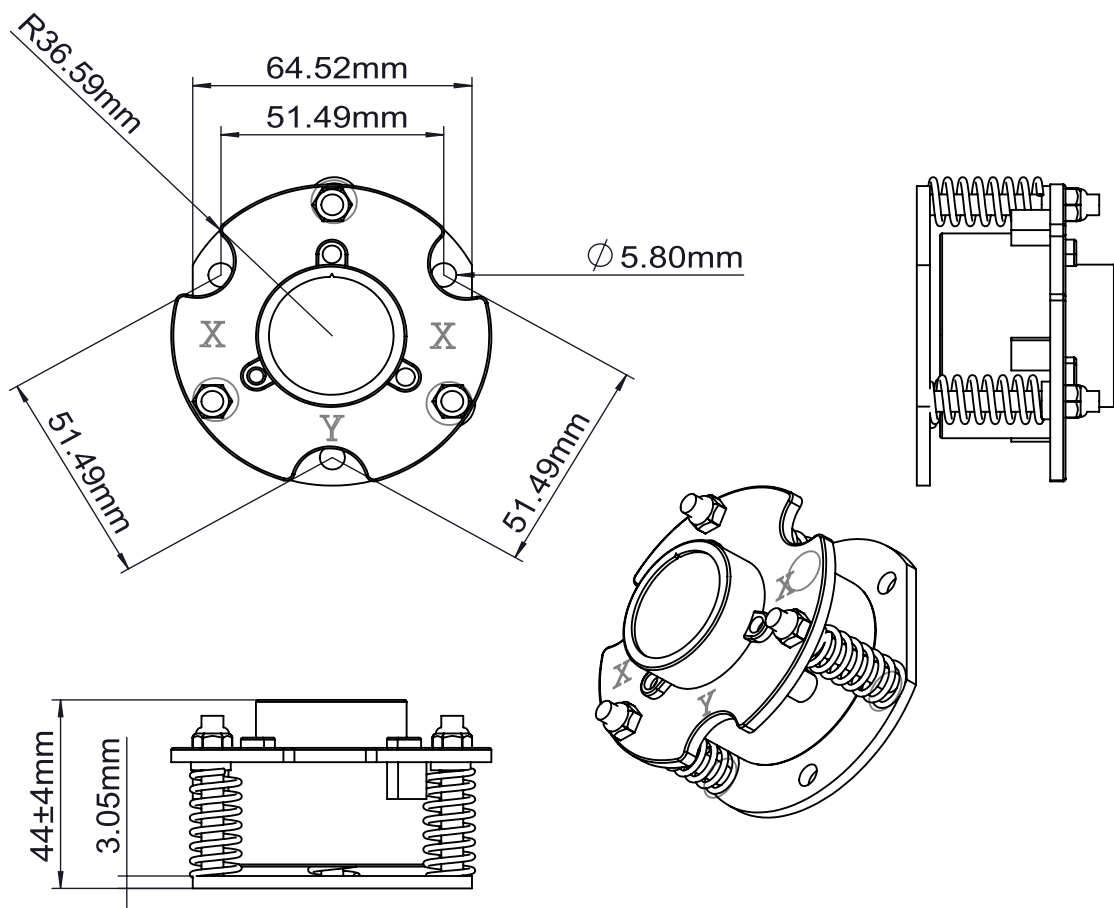

## Interface Definition

Red	Blue	Brown	Black	Yellow
VIN	RXD	TXD	GND	OUT

## Ordering information

WSS	-	①	-	②	-	③	-	④
		XXX		XXX		XX		1X

- ① X-axis alarm angle, if 2.5 degrees alarm is required, it is 025
- ② Y-axis alarm Angle, if 3.0 degrees alarm is required, it is 030
- ③ Alarm delay time, if 1 second alarm delay is required, it is 10
- ④ Level state when alarming, 1L is low level, 1H is high level

## Indicator light description

Condition	Red light	Green light	Comments
Normal	Off	On	Indicates that the angle is within the alarm threshold
Normal turn to alarm	Off	Flashing	Indicates that the angle exceeds the threshold from within the alarm threshold
Alarm	On	Off	Indicates that the angle is outside the alarm threshold
Alarm turn to Normal	Flashing	Off	Indicates that the angle recovers from outside the alarm threshold to within the threshold

## Zero Setting:

1. Find the zeroing hole to the left of the outlet direction.
2. Use the zeroing tool to insert the zeroing hole and hold down the button. You can see the red and green lights flashing alternately (at this time, the zeroing operation can be performed).
3. Keep the red and green lights flashing alternately, while observing the status changes of the indicator lights: from the red and green lights flash alternately and turn into steady red and green light on at the same time, and remove the zero-setting tool until the green light alone is always on;
4. Turn off the power.
5. Turn on the power again, and confirm that the green light is on, indicating that the zero setting operation is successful. If the red indicator is on, it means that the zero-setting operation has failed, and you need to go back to the first step to perform the zero-setting operation again.

### Recommend: Need Zero setting in following situation

1. The sensor has just been installed
2. Compared with the last zero setting, the temperature increased or decreased by more than 15°C

Note: All Specifications are subjected to change without notice.