

WMCS Series High Accuracy 3D Digital Compass

WMCS Series Features >>

- UART/RS232/RS485 output
- Power supply 5V
- Tilt compensation
- Accuracy: 0.3°
- PCBA package
- Operating temperature: -40~85°C
- RoHS

WMCS Series Application >>>

- Unmanned aircraft
- Infrared imager
- GPS integrated navigation
- Petroleum geological exploration
- Optical range finder
- Antenna servo control

Product introduction

Woosens WMCS series high accuracy 3D electronic compass adopts advanced hard iron and soft iron calibration algorithm, which can provide high-precision heading information when both pitch and roll angle at any angle within 360°. Due to its compact size, it is suitable for space-demanding systems.



WMCS series high accuracy 3D digital compass integrates a three-axis magnetic sensor that compensates for the tilt angle with a three-axis accelerometer when the heading is solved in real time by the MCU, providing accurate heading data in Various application environments.

Product specification

◆ Electrical Specification

		Standard	High
		Heading	Accuracy
0.8°Tilt<30°	0.5°Tilt<30°		
2.0°Tilt<80°	1.0°Tilt<80°		
Resolution	0.01°		
	Repeatability	0.05°	
Tilt	Resolution	0.01°	
	Pitch range	±85°	
	Pitch accuracy	0.1°<15° (measure range)	
		0.2°<30° (measure range)	
		0.4°<80° (measure range)	
	Roll range	±180°	
	Roll accuracy	0.1°<15° (measure range)	
0.2°<30° (measure range)			
0.4°<80° (measure range)			
Start delay	<50ms		
Frequency response	20Hz		
Communication rate	2400 to115200 baud		
Communication protocol	Modbus/ASCII		
Power supply	5V		
Operating current	<35mA		
Operating temperature	-40~85°C		
Weight	15g		

Note: The related parameter value is measured at room temperature 25°C.



Mechanical Characteristic

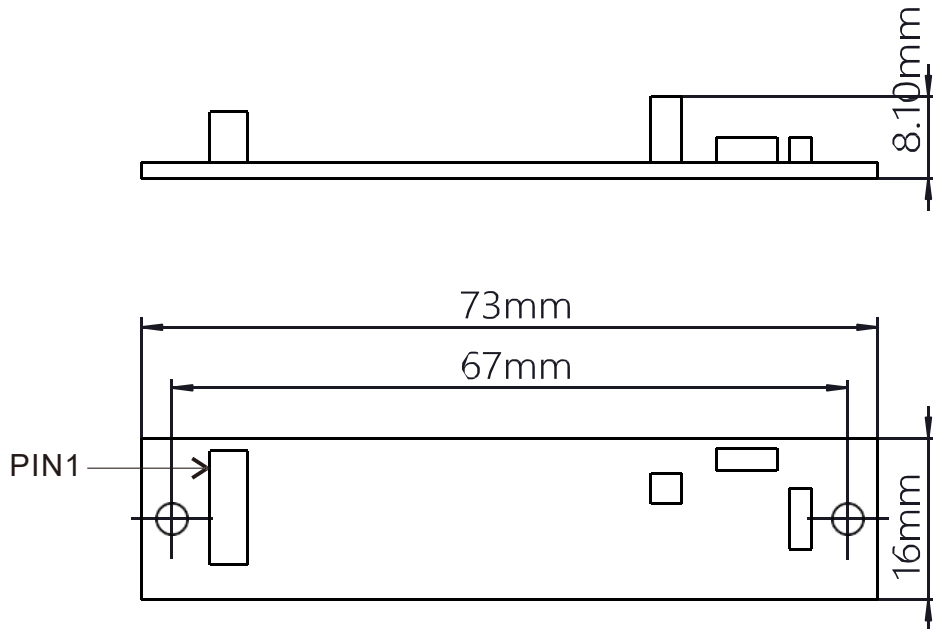

Interface Definition

	PIN1	PIN2	PIN3	PIN4	PIN5
RS232/UART	VCC	NC	GND	RXD	TXD
RS485	VCC	NC	GND	485-A	485-B

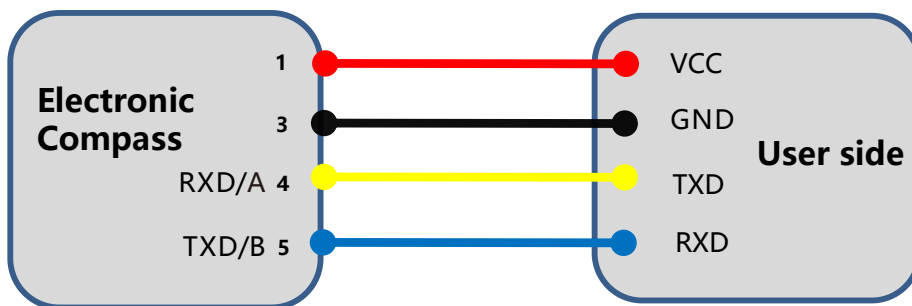

UART,RS232/RS485 wiring diagram



Ordering information

Interface	Standard accuracy	High accuracy
URAT	WMCS230S -V2	WMCS230H -V2
RS232	WMCS233S -V2	WMCS233H -V2
RS485	WMCS235S -V2	WMCS235H -V2

Note: The product wiring type is 11202-053313-021

Installation Guide

WMCS high accuracy 3D digital compass uses a magnetometer to sense the geomagnetic field to calculate the direction, and the earth's magnetic field is easily interfered by the external magnetic field. So users should pay attention to the surrounding magnetic field during installation to ensure that the sensor is exposed to the earth's magnetic field and avoid using it near ferromagnetic materials and changing magnetic fields, such as engines, iron plates, iron bolts and nuts, wires, speakers, etc.

Precautions for installation and calibration:

- 1、 It is important to strictly avoid magnets, motors and other strong magnetic substances within 30cm of the compass, which may cause the measurement accuracy of the compass to irreversibly decrease.
- 2、 After the compass is installed or every time the product's magnetic field environment changes, the product needs to be calibrated.
- 3、 After the compass installation position and the magnetic field environment around the product change, the product needs to be calibrated again.
- 4、 The accuracy of the test compass cannot reach the specifications, and the product needs to be calibrated again.

Installation methods

Woosens provides 24 different installation methods according to the different usage methods of customers. Customers can determine the installation method of the compass according to their own needs to achieve the best effect. The installation method diagram is as follows.

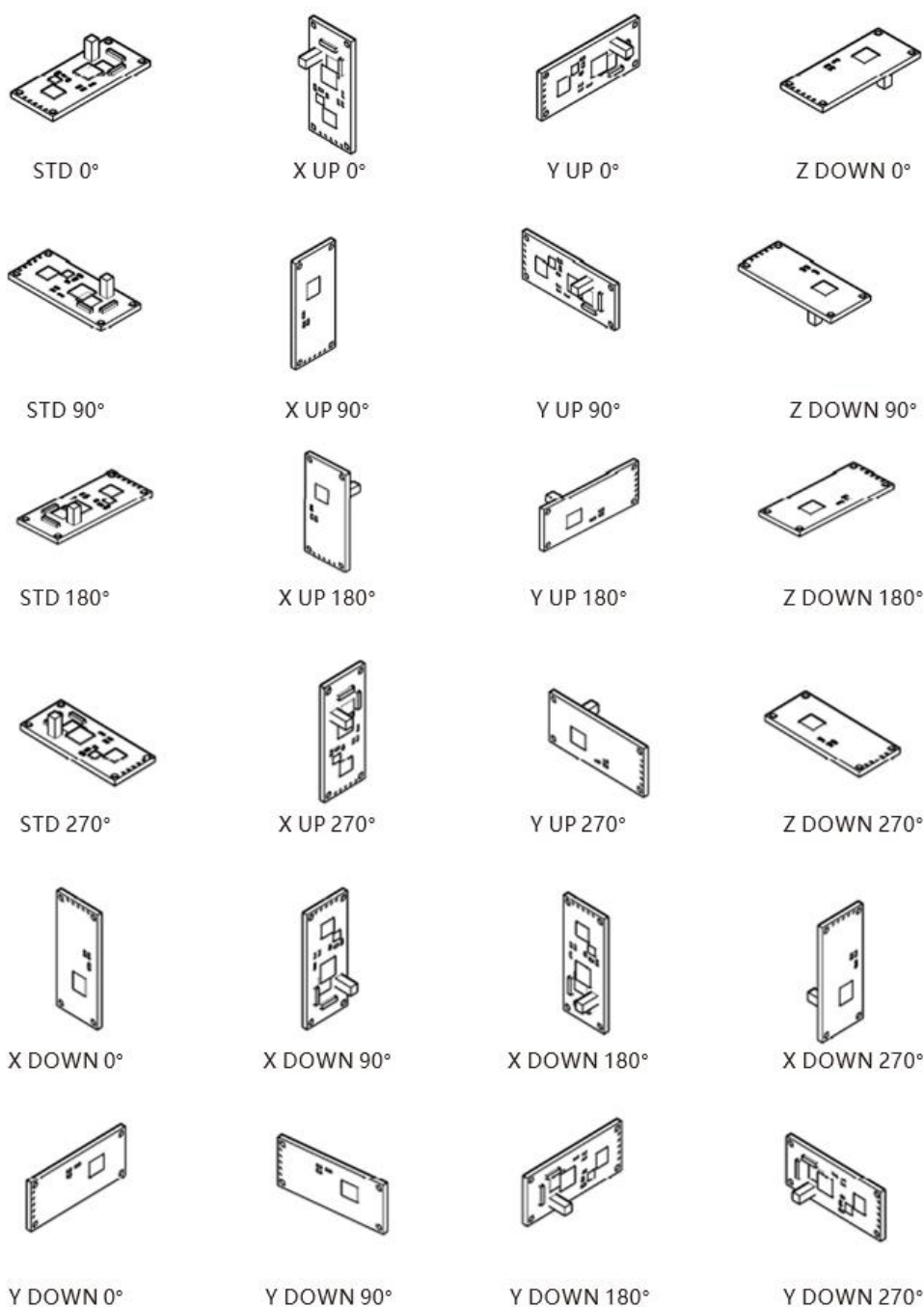



Calibration Method

Calibration method :

(A) Plane calibration

(B) Polyhedral calibration

(C) Modbus Command calibration

(A) Plane calibration

1. Connect the compass to the interface of the product correctly and place it firmly in the use environment. The operator should not carry iron or electronic (such as keys, mobile phones, etc.) magnetic objects during calibration.
2. The product is placed in a horizontal state;
3. Open the Woosens electronic compass user software debugging interface, click "open serial port" (the default serial port baud rate is 19200) after connecting the compass, the software interface displays the actual angle of the current magnetic compass output heading angle, pitch angle and roll angle value. Calibration mode selection 2D Full circle;
4. After clicking "Enter Calibration", the number of sampling points, sampling status, and adopted point display NA will change to 00 and enter the calibration state.
5. Rotate the product in the horizontal plane (both the pitch and roll angles are within $\pm 5^\circ$) around the vertical direction, and rotate 1-2 times, the rotation process should be as slow as possible and nearly uniform.,The time for one rotation about 10 seconds;
6. After step 5, the user's magnetic calibration score will be refreshed, indicating that the calibration is successful;
7. To save the calibration results, click "Save All"

(B) Polyhedral calibration

1. Connect the compass to the interface of the product correctly and place it firmly in the use environment. The operator should not carry iron or electronic (such as keys, mobile phones, etc.) magnetic objects during calibration.
2. Open the Woosens electronic compass user software debugging interface, click "open serial port" (default serial port baud rate is 19200) to connect the compass, the software interface displays the actual angle of the current magnetic compass output heading angle, pitch angle and roll angle value. Calibration mode select 3D Full multi-point, the number of calibration points is 24 (if not, it can be set separately)

3. Click "Enter Calibration"

4. The product is placed in a horizontal state, the installation side is facing upwards, and the data is collected in 4 different directions, including front, rear, left, and right, respectively, after one rotation, each direction pauses for about 1~2 seconds to wait for the calibration point to be collected, after the data collection of the current placement position is successful, the software interface The "Current Calibration Points" will automatically increase by 1;

5. Place the product in a horizontal state with the installation side facing down, and the method is the same as step 4;

6. The product is placed in a vertical state, the installation surface is facing forward, and the method is the same as step 4;

7. The product is placed in a vertical position, with the mounting surface on the left and the side facing forward, the method is the same as step 4;

8. Place the product in a vertical position, with the mounting surface on the right and the side facing forward, the method is the same as step 4;

9. Place the product in a vertical position, with the back of the mounting surface facing forward, and the method is the same as step 4;

Steps 4, 5, 6, 7, 8, and 9 can be exchanged in any order. Refer to the following figure for the six sides.

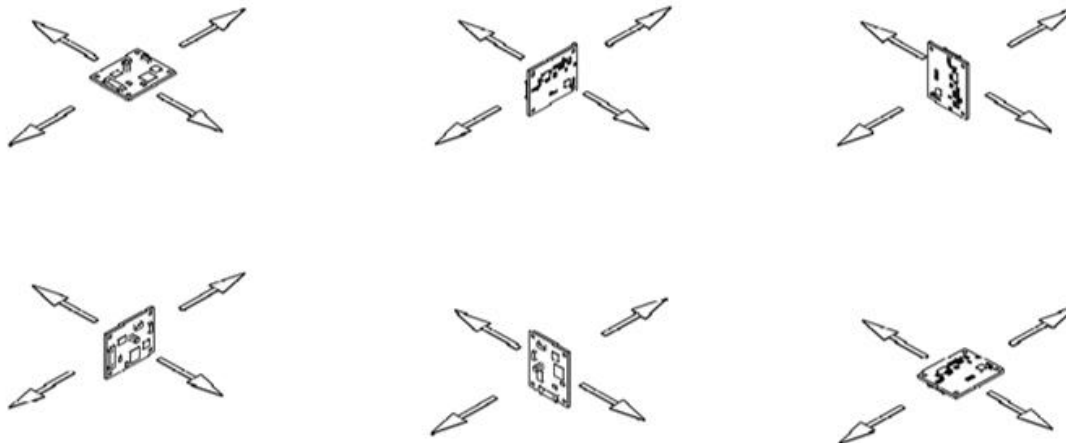

10. After the user's magnetic calibration score is refreshed again, the calibration is successful;

11. To save the calibration results, please click "Save All";

(C) Modbus Command calibration

1. Set the 0027H register (Option), please refer to the compass register address table for specific register description.

2. Set the 0021H register (Cal), write the value 4D53H, the module starts to calibrate and lock the value of this register (4D53H).

3. Move the module to the corresponding position and keep it still.

The program reads the 001FH register (LayCnt), the low byte is the number of points Cnt that has been calibrated, and Cnt equal to 255 indicates that the calibration has failed.

The high byte is the current staying position Lay, Lay equal to 255 indicates non-stationary state, Lay equals to the total set calibration points Num indicates static and unable to determine the current position (need to change the position to solve), Lay is less than the set total calibration points Num indicates the corresponding The position (from 0 to the total number of calibration points minus 1).

In the automatic sampling mode, if the module is stationary, the module will sample data every 2 seconds, and the later value will overwrite the previous value. If it moves to the next sampling point, the module will wait for static re-sampling. Each sampling point, Cnt Will increase by 1.

In manual sampling mode, when Lay is less than Num minus 1, you need to set 0020H register (PickPos) for sampling. The high byte is Pick, and the low byte is Pos. Pick writing a value less than Num will point Pos to Pick. , and write the sampled data to that location; Writing a value equal to Num will write the sampled data to the position pointed by Pos and add 1 to Pos; writing other values is invalid.

4. Repeat the sampling process until the sampling is completed and the calculation result is completed. If the calibration is successful, you can read the 001E register (CalScoreAM). The lower the calibration score, the better. If only one sensor is calibrated, the score of the other sensor is 0. If the calibration fails, the value of this register will not be updated. If you find something wrong in the middle, you can set the 0021H register (Cal), write the value 4D43H, cancel and exit the calibration program, and then you can restart the calibration.

5. If the calibration is successful, you can set the 0022H register (Cmd) and write the value 5553H to save the calibration result.



Communication Protocol

WMCS series three-dimensional electronic compass communication protocol adopts the standard MDOBUS-RTU protocol, which is convenient for customers to be compatible with other standard serial devices in the system.

Data frame format:

Addr	Fun	Data addr reg Hi	Data addr reg Lo	Data #of regs Hi	Data #of regs Lo	CRC16 Lo	CRC16 Hi
01H	03H	01H	08H	00H	02H	44H	35H

Addr:	Slave address
Fun:	Function code
Data addr reg Hi:	Data start address Register high byte
Data addr reg Lo:	Data start address Register low byte
Data #of regs Hi:	Number of data read High byte of register
Data #of regs Lo:	Number of data read Low byte of register
CRC16 Lo:	Low byte
CRC16 Hi:	Cyclic redundancy check high byte

Command format:

For the register address, please refer to the attached table. The following is a description of several commonly used commands

1. Read the azimuth value

Send command: 01 03 00 0A 00 03 25 C9

addr	Fun	Data addr reg Hi	Data addr reg Lo	Data #of regs Hi	Data #of regs Lo	CRC16 Lo	CRC16 Hi
01H	03H	00H	0AH	00H	03H	25H	C9H

Response command: 01 03 06 23 28 03 E8 FC 18 87 5A

addr	Fun	Byte Count	Data1 Lo ~Hi	Data2 Lo~Hi	Data3 Lo~Hi	CRC16 Lo	CRC16 Hi
01H	03H	06H	23H 28H	03H E8H	FCH 18H	87H	5AH

In the above example,

Heading: 0x2328, Decimal 9000, Heading angle is 90.00

Pitch: 0x03E8, Decimal 1000, Pitch angle is 10.00

Roll: 0xFC18, Complement represents a negative number, Roll angle is -10.00



2. Set communication rate

Send command: 01 10 00 25 00 01 02 04

addr	Fun	Data addr reg Hi	Data addr reg Lo	Data #of regs Hi	Data #of regs Lo	Byte Count	Value Hi	Value Lo	CRC16 Lo	CRC16 Hi
01H	10H	00H	25H	00H	01H	02H	04H	00H	A3H	A5H

Response command: 01 10 00 25 00 01 10 02

addr	Fun	Data addr reg Hi	Data addr reg Lo	Data #of regs Hi	Data #of regs Lo	Byte Count
01H	10H	00H	25H	00H	10H	02H

In the above example **04 00**: Set the baud rate is 19200, Refer to Register Table 1, Please read the value of the config register before setting. Only bit[10:8] can be set to ensure that the other bits of the baud rate register are not affected.

3. Set calibration mode

Send command: 01 10 00 27 00 01 02 00

addr	Fun	Data addr reg Hi	Data addr reg Lo	Data #of regs Hi	Data #of regs Lo	Byte Count	Value Hi	Value Lo	CRC16 Lo	CRC16 Hi
01H	10H	00H	27H	00H	01H	02H	00H	18H	A0H	8DH

Response command: 01 10 00 27 00 01 B1 C2

addr	Fun	Data addr reg Hi	Data addr reg Lo	Data #of regs Hi	Data #of regs Lo	CRC16 Lo	CRC16 Hi
01H	10H	00H	27H	00H	01H	B1H	C2H

In the above example, 00 18 are data bits, including setting the correction mode to 3D FULL multi-point, automatic sampling mode, the index of the correction array is 0, and the number of correction points is 24

4. Enter calibration command

Send command: 01 10 00 21 00 01 02 4D 53

addr	Fun	Data addr reg Hi	Data addr reg Lo	Data #of regs Hi	Data #of regs Lo	Byte Count	Value Hi	Value Lo	CRC16 Lo	CRC16 Hi
01H	10H	00H	21H	00H	01H	02H	4DH	53H	D5H	8CH

Response command: 01 10 00 21 00 01 51 C3

addr	Fun	Data addr reg Hi	Data addr reg Lo	Data #of regs Hi	Data #of regs Lo	Byte Count	CRC16 Lo	CRC16 Hi
01H	10H	00H	21H	00H	01H	02H	51H	C3H



5. Read calibration status register

Read the status of registers 0x001E and 0x001F at the same time

send command: 01 03 00 1E 00 02 A4 0D

addr	Fun	Data addr reg Hi	Data addr reg Lo	Data #of regs Hi	Data #of regs Lo	CRC16 Lo	CRC16 Hi
01H	03H	00H	1EH	00H	02H	A4H	0DH

Response command: 01 03 04 00 00 00 01 3B F3

addr	Fun	Byte Count	Data1 Lo ~Hi	CRC16 Lo	CRC16 Hi
01H	03H	04H	00H 00H 00H 01H	3BH	F3H

In the returned data, 01 is the address, 03 is the read operation instruction, 06 is the number of bytes of the returned data, 00 0C (is the value of the 0x001E register, indicating the calibration score, if it has been calibrated before and saved, the current display is the last calibrated Score, can be ignored until calibration is completed).

00 01 (the value of 0x001F) indicates the number of sampled points of the calibration point and the current calibration status. When the high byte is FF, sampling cannot be performed. After stabilization, the high byte value is less than or equal to the number of sampled points before sampling, low Byte 01 means that one point has been sampled. After one point is sampled, the sampling can continue to the next position.

6. Save settings and calibration results command

After the calibration is completed, you need to send the command to save the calibration result.

send command: 01 10 00 22 00 01 02 55 53 DF BF

addr	Fun	Data addr reg Hi	Data addr reg Lo	Data #of regs Hi	Data #of regs Lo	Byte Count	Value Hi	Value Lo	CRC16 Lo	CRC16 Hi
01H	10H	00H	22H	00H	01H	02H	55H	53H	DFH	BFH

Response command: 01 10 00 22 00 01 A1 C3

addr	Fun	Data addr reg Hi	Data addr reg Lo	Data #of regs Hi	Data #of regs Lo	CRC16 Lo	CRC16 Hi
01H	10H	00H	22H	00H	01H	A1H	C3H

In the above example, 55 53 is the command to save the calibration command, save the previous calibration data, and exit the calibration mode.



Compass register address table:

Address	R&W	Name	Type	Explanation
0000H	RO		Float32	Reserve
0002H	RO		Float32	Reserve
0004H	RO		Float32	Reserve
0006H	RO		Float32	Reserve
0008H	RO		UInt16	Reserve
0009H	RO	Inclination	Int16	Magnetic inclination output: -9000 ~ +9000, corresponding to -90.00 ~ +90.00 degree
000AH	RO	Yaw	Int16	Heading: 0(-18000) ~ 35999(+18000) corresponding to 0.00(-180.00) ~ 359.99 (+180.00)degree, See register Config [bit13];
000BH	RO	Pitch	Int16	Pitch: -9000(-18000) ~ 9000(+18000) corresponding to -90.00(-180.00)~ +90.00 (+180.00)degree, See register Config [bit14];
000CH	RO	Roll	Int16	Roll: -18000~+18000 corresponding to -180.00~+180.00 degree;
000DH	RO	Disturbance	UInt16	Magnetic interference
000EH	RO		UInt16	Reserve
000FH	RO		UInt16	Reserve
0010H	RO	MX	Int16	Magnetometer X-axis raw value
0011H	RO	MY	Int16	Magnetometer Y-axis raw value
0012H	RO	MZ	Int16	Magnetometer Z-axis raw value
0013H	RO		UInt16	Reserve
0014H	RO	AX	Int16	Accelerometer X-axis raw value
0015H	RO	AY	Int16	Accelerometer Y-axis raw value
0016H	RO	AZ	Int16	Accelerometer Z-axis raw value
0017H	RO		UInt16	Reserve
0018H	RO		Int16	Reserve
0019H	RO		Int16	Reserve
001AH	RO		Int16	Reserve
001BH	RO		UInt16	Reserve
001CH	RO		UInt16	Reserve
001DH	RO	CalScoreF	UInt16	Low byte: freely calibrate the magnetometer score, high byte: reserved, read as 0;
001EH	RO	CalScoreAM	UInt16	Low byte: user calibrating magnetometer score, high byte: user calibrating accelerometer score;
001FH	RO	LayCnt	UInt16	Low byte: Calibration sampling count Cnt, 255 means calibration failed. High byte: calibration placement position Lay, 255 means data is unstable; equal to the number of calibration points means stable but unable to judge the position; less than the number of calibration points means the corresponding position
0020H	RW	PickPos	UInt16	Low byte: sampling position Pos, high byte: sampling select Pick (manual), can only be written when read as 255, writing a value less than the number of calibration points num will point Pos to the position pointed by Pick, and sample the data Write to this position; writing a value equal to the number of calibration points num will write the sampled data to the position pointed by Pos and increase Pos by 1; writing other values is invalid
0021H	RW	Cal	UInt16	00xxH->Command is successful, return xx standby; FFxxH->Command fails, return xx standby; 4D53H->enter calibration mode; 4D43H->calibration cancel;



Address	R&W	Name	Type	Explanation
0022H	RW	Cmd	UInt16	00xxH->Command success returns xx standby, FFxxH->command failure returns xx standby, 4E53H->Set North, 4E43H->Clear North, 4253H->Set offset, 4243H->Clear offset, 5552H->Reset, 5553H-> Save, 554CH->load, 5544H->default;
0023H	RW		UInt16	Reserve
0024H	RW	Addr	UInt16	Low byte: modbus address (1-254), high byte: reserved, read as 0;
0025H	RW	Config	UInt16	bit[4:0]: Installation method (0~23); bit[7:5]: Filter coefficient $n(2^n)$; bit[10:8]: Baud(0->2400, 1->4800, 2->9600, 3->14400, 4->19200, 5->38400, 6->57600, 7->115200); bit[12:11]: ODR(0->10Hz, 1->25Hz, 2->50Hz, 3->50Hz); bit[13]: 0->Yaw 0~360 度, 1->Yaw +/-180 度; bit[14]: 0->Pitch +/-90 度, 1->Pitch +/-180 度; bit[15]: 0->Free Cal Disable, 1->Free Cal Enable;
0026H	RW	Ctrl	UInt16	Reserve
0027H	RW	Option	UInt16	bit[7:0]: number of calibration points (multi-point mode) num; bit[10:8]: number of calibration groups index idx; bit[11]: 0->automatic sampling, 1->manual sampling; bit[15:12]: Calibration mode (0->3D Full multipoint, 1->3D Hard multipoint, 2->3DLimit multipoint, 3->2D Full multipoint, 4->3D Full rotation, 5->3D Hard circle, 6->3D Limit circle, 7->2D Full circle, 8->ACC Only, 9->ACC+MAG);
0028H	RW	Declination	Int16	Magnetic declination setting (+E -W): -18000 ~ +18000 corresponds to -180.00 ~ +180.00 degrees;
0029H	RW	Inclination	Int16	Magnetic inclination setting (+D -U): -9000 ~ +9000 corresponds to -90.00 ~ +90.00 degrees;
002AH	RW	Yawbias	Int16	Heading angle offset: -18000 ~ +18000 corresponds to -180.00 ~ +180.00 degrees;
002BH	RW	Pitchbias	Int16	Pitch angle offset: -18000 ~ +18000 corresponds to -180.00 ~ +180.00 degrees;
002CH	RW	Rollbias	Int16	Roll angle offset: -18000 ~ +18000 corresponds to -180.00 ~ +180.00 degrees;
002DH	RW	User	UInt16	Open to users, can be saved;
002EH	RW		UInt16	Reserve
002FH	RW		UInt16	Reserve

Note: All Specifications are subjected to change without notice.